

Users Manual

Model 16 Cryo-Plex[®]

High Vacuum Cryopump



Austin Scientific is a wholly-owned subsidiary of Oxford Instruments. For information about Oxford Instruments, visit the Oxford Instruments Web site at:

<http://www.oxford-instruments.com/>

How to Contact Austin Scientific Support:

For contact information and a complete listing of Direct Sales, Distributor, and Sales Representative contacts, visit the Austin Scientific Web site at:

<http://www.austinscientific.com/>

Austin Scientific has made its best effort to ensure that the information contained in this document is accurate and reliable. However, the information is subject to change without notice and is provided "AS IS" without warranty of any kind (express or implied). Before placing orders, customers are advised to obtain the latest version of relevant information to verify that information being relied upon is current and complete. All products are sold subject to the terms and conditions of sale supplied at the time of order acknowledgment, including those pertaining to warranty, patent infringement, and limitation of liability. No responsibility is assumed by Austin Scientific for the use of this information, including use of this information as the basis for manufacture or sale of any items, nor for infringements of patents or other rights of third parties.

This document is the property of Austin Scientific and by furnishing this information, Austin Scientific grants no license, express or implied, under any patents, copyrights, trademarks, trade secrets, or other intellectual property rights of Austin Scientific. Austin Scientific, copyright owner of the information contained herein, gives consent for copies to be made of the information only for use within the customer's organization as related to the use of Austin Scientific products. The same consent is given for similar information contained on any Austin Scientific Web site or disk used to distribute information to a customer. Austin Scientific does give consent to the copying or reproduction by any means of the information contained herein for general distribution, advertising or promotional purposes, or for creating any work for resale. The names of products of Austin Scientific or other vendors and suppliers appearing in this document may be trademarks or service marks of their respective owners that may be registered in some jurisdictions. A list of Austin Scientific trademarks and service marks can be found at: <http://www.austinscientific.com/>.

Austin Scientific
An Oxford Instruments Company
4114 Todd Lane
Austin, Texas 78744 USA
TEL. +1 512 441 6893
FAX +1 512 443 6665
Email: Info@austinscientific.com

Copyright (©) 2006 by Oxford Instruments, All rights reserved.

Contents

1	Preface	1-1
1.1	About Austin Scientific.....	1-1
1.2	Other Services from Austin Scientific	1-1
1.3	About this Manual.....	1-1
1.4	Compatibility.....	1-2
2	Troubleshooting	6-1
2.1	Troubleshooting Activities.....	6-1
7	Operations and Controls	5-1
7.1	Model 16 Cryopump Operations.....	5-1
7.1.1	Cryopump Preparation.....	5-1
7.1.2	Normal Operation	5-1
7.1.2.1	Cryopump Start-up	5-1
7.1.2.2	Rough Pumping	5-1
7.1.2.3	Regeneration of the Cryopump.....	5-2
8	Installation	4-1
8.1	Safety Warnings	4-1
8.2	Inspect Equipment before Installing	4-1
8.3	Tools Needed for Installation.....	4-1
8.4	Installing the Model 16 Cryopump	4-1
8.5	Installing a Roughing Pump.....	4-2
5	Introduction	3-1
5.1	General Information about the Model 16 Cryopump	3-1
5.1.1	Model 16 Cryopump Features	3-1
5.2	Specifications	3-2
5.3	Ordering Information.....	3-6
5.3.1	Standard Equipment and Accessories.....	3-6
5.3.2	Optional Accessories and Replacement Parts.....	3-6
4	Safety Warnings	2-1
4.1	Safety Warnings	2-1
4.1.1	Standards for the Use of Warnings and Cautions.....	2-1
4.1.2	Warnings Applicable to All Aspects of the Operation of Model 16 Cryopumps	2-1
4.1.3	Operator Instructions	2-1
5	Maintenance	7-1
5.1	Maintenance Personnel Requirements	7-1
5.2	Tools Needed to Service the Model 16 Cryopump.....	7-1
5.3	Scheduled Preventative Maintenance	7-1
5.3.1	Preparation Before Decontamination.....	7-1
5.3.2	Purging the Regulator and Charging Line	7-1
5.3.3	Pressurize and Vent the Cold Head	7-1
5.3.4	Reconnect Gas Lines to Complete Decontamination	7-2
5.4	Cleaning Equipment	7-2

5.5 Returning Equipment.....7-2

Figures

3-1 Model 16 Cryopump 3-3
 3-2 Dimensions of Model 16 Cryopump with ISO Flange 3-4
 3-3 Dimensions of Model 16 Cryopump with CVC Flange..... 3-5
 4-1 Connection Diagram 4-2

Tables

3-1 CP16 Physical Characteristics.....3-2
 3-2 Model 16 Cryopump Ordering Information3-6
 3-3 Optional Accessories and Replacement Parts3-6
 6-1 Troubleshooting Procedures.....6-2

Revision History

Date	Revision	Description
October 2006	1.0.1	Conversion to new format.

Preface

1

1.1 About Austin Scientific

Austin Scientific, a wholly-owned subsidiary of Oxford Instruments, specializes in the manufacture and repair of cryogenic vacuum pumps, cryocoolers (refrigerators) and helium compressors for semiconductor, optical coating, linear accelerators, medical equipment, and R&D applications.

You can find just what you need from our range of products and support services.

- New equipment - cryopumps, such as the Model 16 cryopumps described in this manual, compressors, cryocoolers, and cryopump controllers.
- Comprehensive range of accessories for the installation of whole systems and a complete range of spare parts to repair cryopumps and compressors.

1.2 Other Services from Austin Scientific

Austin Scientific offers a broad range of additional services:

- *Repair and refurbishment services* - Whatever brand of cryo-components you have, we offer fully warranted refurbishment, often with off-the-shelf availability.
- *Exchanges* - We offer our own quality products, as well as most makes of cryopumps and helium compressors, which are refurbished and fully warranted.
- *Technical Support* - Our support engineers will help determine if your cryopump system is operating correctly so that you can get your system back to optimum efficiency as soon as possible.

To contact Austin Scientific Technical Support:

Email: support@austinscientific.com

- Telephone: 1-512-441-9258 or Toll Free: 1-800-404-1055
- *Installation* - On-site installation services are available to guarantee performance and save you time.
- *Training* - We offer on-site training to help you and your staff to know more about your cryopump and compressor systems. Our training will give you confidence and the ability to maintain a highest possible uptime for your system.

1.3 About this Manual

The purpose of this manual is to provide our customers using the Model 16 Cryopumps with information needed to safely and efficiently operate the cryopump when operating as part of a cryogenic refrigeration system. Such a system is often comprised of the following equipment:

- Cryopump compressor unit such as the Model 600 compressor from Austin Scientific
- Coldhead/cryopump
- Connecting helium lines.

This manual describes the design, operation and maintenance of a CP16 cryopump unit.

1.4 Compatibility

The Model 16 cryopumps are designed for use with Austin Scientific Model 600 helium compressor (or equivalent).

Safety Warnings

2

2.1 Safety Warnings

2.1.1 Standards for the Use of Warnings and Cautions

Warnings are noted when there is a possibility of injury or death to persons operating the equipment or performing specific tasks or procedures noted in this manual.

Cautions are noted when there is a possibility of damage to equipment if the caution is ignored.

2.1.2 Warnings Applicable to All Aspects of the Operation of Model 16 Cryopumps

Warning If the Model 16 cryopump has been used to pump any toxic or dangerous materials, this information and associated paperwork must be listed on all shipping containers and on associated paperwork before the equipment is returned to Austin Scientific for any repairs.

Warning When pumping any toxic, corrosive, or flammable gases, a vent pipe must be connected to the cryopump relief valve and vented to a safe location.

Warning Do not install a hot filament vacuum gauge on the cryopump side of the hi-vac gate valve as this could be a source of ignition.

Warning Helium gas can cause rapid asphyxiation and death if released in a confined area.

Warning Use a pressure reducing regulator when with-drawing Helium gases from a high pressure cylinder

Warning Detaching the helium flex lines with the compressor load at low temperature can cause the pressure rise in the system beyond the permissible level therefore creating a safety hazard.

2.1.3 Operator Instructions

Follow standard CP16 operating procedures as described in this manual. If after reading this manual, you still have questions regarding the safe operation of the CP16 cryopump, please contact Austin Scientific Technical Support using the contact information found in [Chapter 1, Section 1.2](#).

Introduction

3

3.1 General Information about the Model 16 Cryopump

Austin Scientific provides both custom and industry standard cryogenic solutions at highly competitive prices. Cryogenic vacuum pumps provide clean, oil-free high vacuum with high pumping speeds are the pump of choice for sputtering, electron beam evaporation, accelerator beam lines and many aerospace and coating applications.

Model 16 cryopumps are available in two standard inlet flange types - ISO and CVC, with temperature sensors either in diode or hydrogen-vapor-bulb (HVB) configurations.

3.1.1 Model 16 Cryopump Features

The Model 16 cryopumps, as seen in [Figure 3-1](#), are typically used in the following applications:

- Sputtering tools
- Ion implanters
- R & D bell-jar systems
- Surface analysis
- Accelerators
- Beam lines
- General vacuum systems

3.2 Specifications

This section describes the specifications for the Model 16 cryopumps.

Table 3-1. CP16 Physical Characteristics

Characteristic	ISO Flange	CVC Flange
Height	23.1 inches	23.2 inches
Maximum Flange Diameter	17.7 inches	18.0 inches
Weight	160 lbs	160 lbs

- Pumping Speeds (liter/sec.)
 - Air: 5000
 - Water: 16000
 - Hydrogen: 5000
 - Argon: 4200
- Argon Throughput
 - 500 scc/min.
- Capacity:
 - Argon: 2000 standard liters
 - Hydrogen: 15 standard liters @ 5x10e-6 torr
- Crossover: 300 torr-liters
- Typical Cool Down Time (From room temperature to 20K):
 - 2.5 hours (60Hz)
 - 3.5 hours (50Hz)
- Inlet Flange (Size: Standard)
 - 16-inch: CVC
 - NW 400: ISO

Note: Model 16 cryopumps can operate safely in any mounting orientation.

Figure 3-1. Model 16 Cryopump



Figure 3-2. Dimensions of Model 16 Cryopump with ISO Flange (Larger Print at the End of Manual)

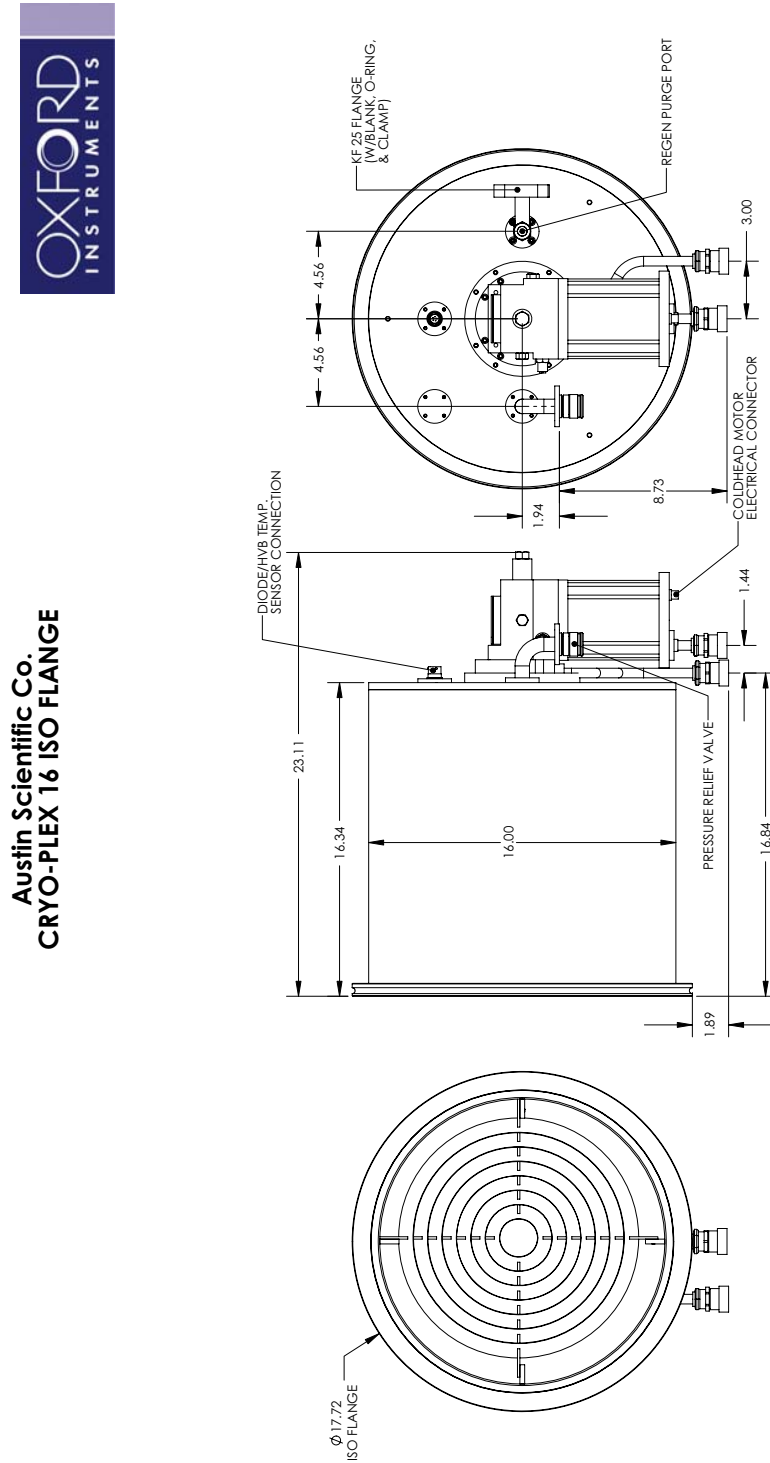
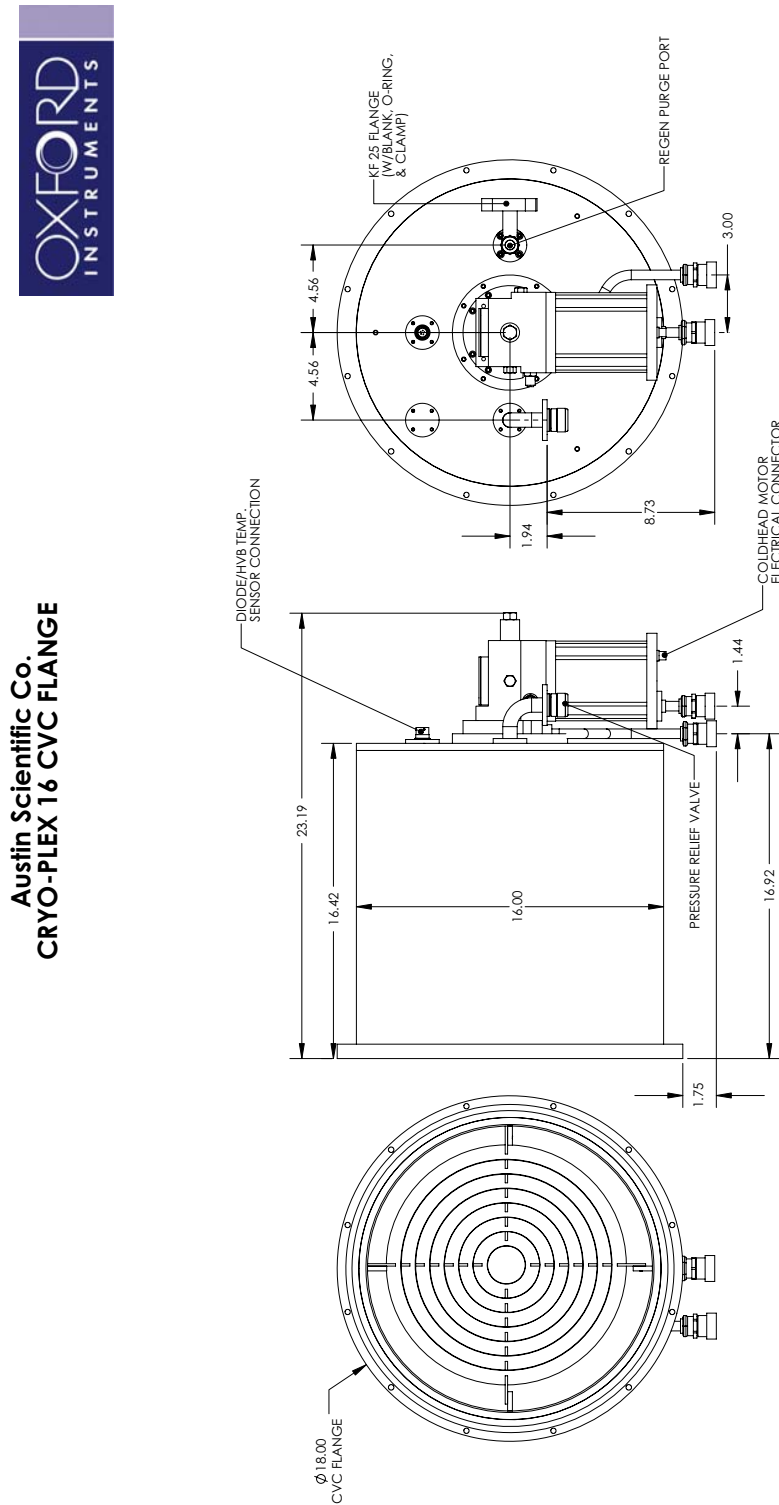

Figure 3-3. Dimensions of Model 16 Cryopump with CVC Flange (Larger Print at the End of Manual)



Austin Scientific Co.
CRYO-PLEX 16 CVC FLANGE



3.3 Ordering Information

3.3.1 Standard Equipment and Accessories

Table 3-2 contains the ordering information for the Model 16 cryopumps.

Table 3-2. Model 16 Cryopump Ordering Information

Cryopump	Part Number
Cryo-Plex 16 (CVC Flange, Diode)	10301
Cryo-Plex 16 (CVC Flange, HVB)	10302
Cryo-Plex 16 (ISO Flange, Diode)	10303
Cryo-Plex 16 (ISO Flange, HVB)	10304

3.3.2 Optional Accessories and Replacement Parts

The customer can order the optional accessories and replacement parts listed in Table 3-3.

Table 3-3. Optional Accessories and Replacement Parts

Accessories/Replacement Parts	Part Number
Blanket heater for CP16	BH-16
Purge gas valve	10185
Purge gas valve heater	10340
Rough valve	10191
Burst disc	BD-133
Relief valve cover	60210
Drive unit power cable (10 ft.*)	10144-10
Diode monitor	10132
Diode cable for diode monitor (10 ft.*)	10133-10
Model 2100 Automatic Cryopump Controller	10310
CP16 Installation Kit	10251

*Custom length available.

Installation

4

4.1 Safety Warnings

Review the safety warnings found in [Chapter 2](#) before starting any installation activities.

4.2 Inspect Equipment before Installing

Remove the cryopump from the box and inspect for any damage during shipping. Notify Austin Scientific immediately if any damage was found.

4.3 Tools Needed for Installation

The Installation Kit for the Model 16 cryopump is offered as an optional accessory that can be ordered from Austin Scientific. Refer to [Chapter 3, Section 3.3](#) for the part number.

4.4 Installing the Model 16 Cryopump

Follow these steps to install the Model 16 cryopump.

1. Clean all sealing surfaces, apply a thin film of vacuum grease to inlet flange o-ring and install it.
2. Bolt cryopump to the chamber hi-vac gate valve.
3. Attach roughing valve to the KF 25 flange on the purge tube adaptor of the cryopump.
4. Remove dust plugs from any Aeroquip Self Sealing Couplings and inspect gasket seals.
5. Connect helium gas lines in the following order.
 - a. Use a helium flexline to connect the “Return” ports on both the Model 16 and the compressor.
 - b. Use a helium flexline to connect the “Supply” ports on both the Model 16 and the compressor.
6. Check gas pressure gauge per compressor specifications.
7. Connect cold-head drive cable from cryopump to compressor.
8. Connect diode cable to temperature monitor if applicable.
9. Connect main power cable per compressor specifications.

[Figure 4.1](#) shows a typical installation diagram when making connections.

Figure 4-1. Connection Diagram

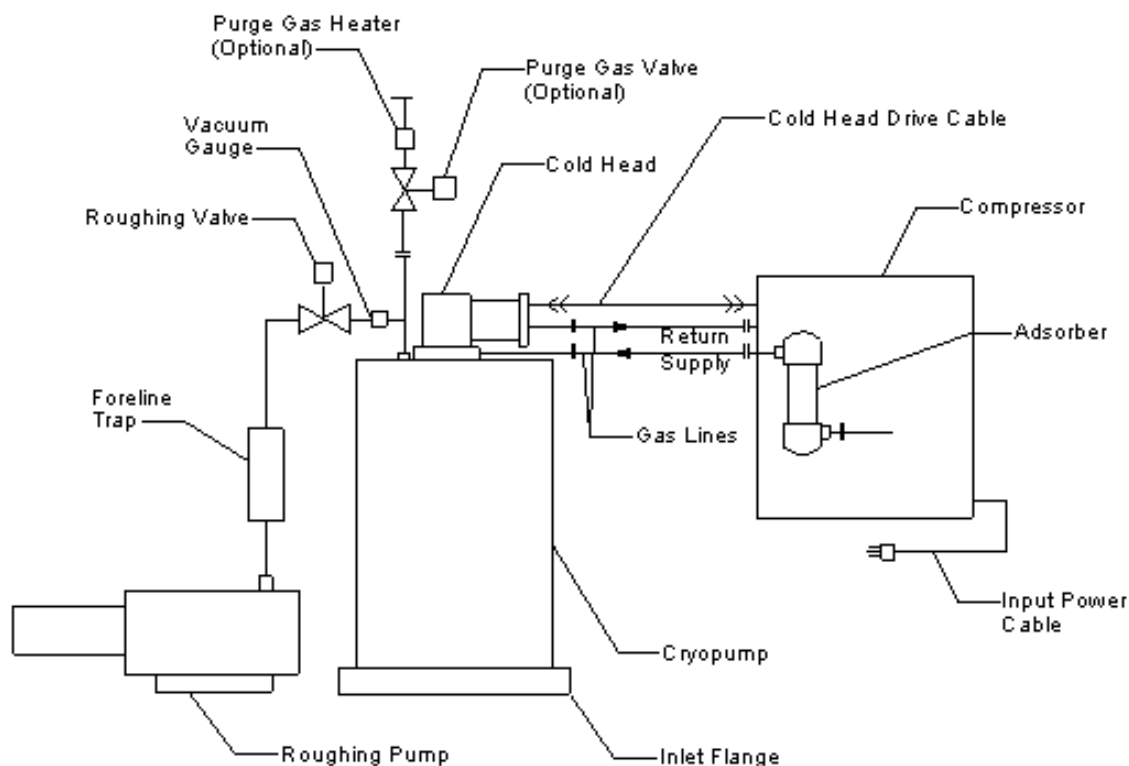

4.5 Installing a Roughing Pump

To install a roughing pump, follow these steps:

1. Connect the roughing pump system directly to the accessory port located on the cryopump.
2. A vacuum gauge and roughing valve should be installed as close as possible to the cryopump.
3. Install an oil backstreaming device (foreline trap) in series to the roughing pump.

Operations and Controls

5

5.1 Model 16 Cryopump Operations

5.1.1 Cryopump Preparation

When a cryopump has been in storage for a period of time or when receiving a new one, the charcoal array of the cryopump may be loaded with moisture or other contaminants. A so-called “Extended Nitrogen Purge” process should be performed to get the cryopump to its desired condition before cool-down operation.

Follow these steps of the “Extended Nitrogen Purge” process:.

1. Install the cryopump per procedures described in [Chapter 4, Section 4.4](#), leak check all mounting seals and valves to ensure the cryopump is leak-tight.
2. Make sure the cryopump is at room temperature.
3. Using a gas supply flexline with proper connections to connect a nitrogen gas (N₂) cylinder (with a pressure regulator) to the purge gas valve of the cryopump.
4. Open the purge gas valve and regulate the pressure of nitrogen gas to between 18 to 30 psi.
5. Turn on the purge gas heater.
6. Continue the purging process for at least 4 hours.
7. Turn off the purge gas heater and close the purge gas valve.
8. Clean and then remount the o-ring of the relief valve on the cryopump.

The cryopump unit is now ready for start-up operation.

5.1.2 Normal Operation

5.1.2.1 Cryopump Start-up

1. Make sure the gate valve to the main chamber is closed.
2. Open the rough valve of the cryopump and rough to appropriate crossover pressure level.
3. Perform Rate of Rise test to verify proper regeneration and leak rate of the cryopump. Normally a 10 micron/minute rate of rise is considered acceptable. If the Rate of Rise test fails, leak check the cryopump and the gate valve first and fix any leak that is present. If the test still fails after that, repeat the “Extended Nitrogen Purge” process described in [Section 5.1.1](#).
4. Rough pump the cryopump back to its appropriate crossover pressure level.
5. Close the rough valve and start the compressor that runs the cryopump.
6. When a cryopump is operating properly, it usually takes about 120~150 minutes to reach 20K.
7. Once the cryopump reaches its operating cryogenic temperature, observe the pressure in the main vacuum chamber before opening the gate valve and starting cryopumping the chamber.
8. The crossover of the main vacuum chamber from rough pump to cryopumping should be at 300 torr-liters. Only open the gate valve when this condition is met.

5.1.2.2 Rough Pumping

Observe the following cautions when rough pumping the cryopump:

Caution: *Do not begin to rough pump the cryopump without knowing the pre-determined roughing pressure.*

Caution: *Never rough pump the cryopump longer than necessary, it could result in back-streaming of mechanical pump oil that will contaminate the cryopump.*

5.1.2.3 Regeneration of the Cryopump

Since cryopumps are capture type pumps, they must be periodically warmed up and evacuated in order to remove the accumulated condensed and adsorbed gases. The process of warming up and evacuating gases from a cryopump is called regeneration.

5.1.2.3.1 Unassisted Regeneration

1. Close the high vacuum gate valve and turn off the compressor and cryopump.
2. The cryopump condensing arrays should be allowed to warm up to 80°F (26°C, 300K).
3. Begin roughing the cryopump to the crossover pressure, close roughing valve and restart compressor and cryopump.
4. Cryopump is now ready for cool-down.

5.1.2.3.2 Assisted Regeneration

1. Close the high vacuum gate valve and turn off the compressor and cryopump.
2. Using a heated dry gas (nitrogen/argon) to purge the cryopump through the purge gas valve. The purge gas should be injected at 1 to 2 cfm and a maximum temperature of 150°F(65°C,338K). Austin Scientific offers a purge gas valve heater option that can limit the heated purge gas temperature to 150°F.
3. The exterior of the cryopump may be heated using a blanket heater available from Austin Scientific Co. (P/N BH-16). Never let the surface exceed 150°F(65°C).
4. When the temperature sensor of the cryopump reaches 80°F (26°C, 300K), discontinue the regeneration process, rough the cryopump to the initial starting pressure, close the roughing valve and restart compressor and cryopump.
5. Cryopump is now ready for cool-down procedures.

5.1.2.3.3 Automatic Regeneration

Automatic regeneration of the cryopump can be accomplished by the use of the Model 2100/2200 Automatic Cryopump Controller, available from Austin Scientific. Automatic regeneration occurs when predetermined pressure or temperature set points are exceeded.

Troubleshooting

6

6.1 Troubleshooting Activities

Table 6-1 describes some problems that users might encounter while operating the Model 16 Cryopump and provides solutions to those problems.

Table 6-1. Troubleshooting Procedures

Problem	Possible Cause	Corrective Action
High base pressure of vacuum system and the cryopump temperature is below 20K.	<ol style="list-style-type: none"> 1. Vacuum leak in vacuum system or in cryopump. 2. High partial pressure of non-condensable (helium, hydrogen, or neon) within the cryopump because the charcoal array of the cryopump has reached full capacity. 	<ol style="list-style-type: none"> 1. Check the following for leaks: <ul style="list-style-type: none"> • Check the vacuum chamber and hi-vac/gate valve for leaks • Check cryopump relief valve for proper seating • Check cryopump for leaks (after closing the gate valve) 2. Regenerate the cryopump per Chapter 5, Section 5.1.2.3
High base pressure of vacuum system, and the cryopump temperature is above 20K.	<ol style="list-style-type: none"> 1. High partial pressure of non-condensable (helium, hydrogen, or neon) within the cryopump because the 15K array has reached full capacity. 2. Excessive thermal load. 3. Decrease in cryopump cold head performance. 	<ol style="list-style-type: none"> 1. Regenerate the cryopump using the instructions in Chapter 5, Section 5.1.2.3. Recool the cryopump, making note of: <ul style="list-style-type: none"> • Cooldown time to the operating temperature • Time to achieve the desired operating vacuum level of the cryopump Compare these figures to those indicated in the operating log. If they are significantly different, then refer to Possible Cause 3 of this problem, "Decrease in cryopump cold head performance". 2. Reduce the thermal radiation load by: <ul style="list-style-type: none"> • Shielding the cryopump • Lowering the temperature of the radiating surface 3. If the helium pressure gauge reads below the normal-operating pressure, add helium gas according to procedure described in the compressor manual. Regenerate and recool the cryopump. If the temperature remains above 20K, the problem may be within the cold head and contact Austin Scientific for assistance.
Cryopump fails to cool down to the required operating temperature or takes too long to reach that temperature.	<ol style="list-style-type: none"> 1. Low helium supply pressure. 2. Vacuum leak in vacuum system or cryopump. 3. High partial pressure of non-condensable (helium, hydrogen, or neon) within the cryopump. 4. Compressor problem. 	<ol style="list-style-type: none"> 1. Add helium gas according to procedure described in the compressor manual. 2. Check vacuum system for leaks: <ul style="list-style-type: none"> • Check cryopump relief valve for proper seating • Check cryopump for leaks 3. Regenerate the cryopump as described in Chapter 5, Section 5.1.2.3. 4. Refer to the "Troubleshooting" section of the compressor manual.
Cryopump has intermittent ratcheting or thumping sound during operation.	<ol style="list-style-type: none"> 1. Helium gas contamination 	<ol style="list-style-type: none"> 1. Refer to Chapter 7, Section 7.3.1. for instructions on how to decontaminate the cryopump.

Maintenance

7

7.1 Maintenance Personnel Requirements

Only trained and qualified personnel should perform the maintenance procedures described in this chapter. Observe safety warnings described in [Chapter 2](#). All other maintenance work must be performed by Austin Scientific personnel in the factory. Please contact Austin Scientific to make arrangement for such work. See contact information in [Chapter 1, Section 1.2](#).

Caution: *Always use two wrenches when connecting or disconnecting the Aeroquip self-sealing couplings.*

7.2 Tools Needed to Service the Model 16 Cryopump

The following tools are needed to carry out the maintenance activities described in this chapter. Refer to [Chapter 3, Section 3.3](#) for the correct part number:

- Maintenance manifold
- Two self-sealing coupling wrenches

7.3 Scheduled Preventative Maintenance

7.3.1 Preparation Before Decontamination

1. Cool down the cryopump for at least one (1) hour.
2. Shut down the compressor and cryopump. Then immediately disconnect the supply and return gas lines from the compressor.
3. Connect the supply and return helium gas lines to the maintenance manifold. Use the manifold to reduce the pressure in the coldhead to 45 psig.
4. Allow the second stage of the coldhead to warm to 80°F (26°C, 300K). Purging the pump with a warm dry gas (argon or nitrogen) will reduce the time required to warm up the pump.

7.3.2 Purging the Regulator and Charging Line

1. Prior to opening the gas cylinder valve, turn the regulator adjustment screw clockwise until it is open.
2. Open the gas cylinder valve. Close the regulator adjustment screw. This will purge air from the gas charging line and the regulator.
3. Connect the gas charging line to the flare fitting attached to the valve on the maintenance manifold. Do not tighten.
4. Follow Steps 1 and 2 in this subsection for at least 30 seconds allowing gas to flow from the flare fitting. With gas still flowing, tighten the flare fitting.

7.3.3 Pressurize and Vent the Cold Head

Follow these steps to vent the cold head:

1. Open the gas cylinder regulator and pressurize the cold head to the static pressure of the compressor. Open the maintenance manifold valve and close when pressure has been reached.
2. Slowly open the valve on the manifold. Release the pressure to no less than 30 psig.
3. Repeat Steps 1 and 2 in this subsection three more times.
4. Repressurize the coldhead to compressor static pressure. Turn on the drive motor for 1 to 2 minutes.

5. Repeat Steps 2 through 4 in this subsection three more times to complete total 12 flushes and 4 drive motor runs.
6. Make sure the helium gas pressure level of the coldhead is charged per compressor static pressure specification.

7.3.4 Reconnect Gas Lines to Complete Decontamination

Disconnect both gas lines from manifold and reconnect to supply and return fittings on the compressor. The cryopump is now ready for cool-down procedures.

7.4 Cleaning Equipment

Caution: *Do not use solvents to clean the connectors. The fittings should never be greased or oiled. Otherwise the helium gas circuit of the system could become contaminated.*

7.5 Returning Equipment

Before returning any equipment, contact Austin Scientific to receive special instructions and to obtain a return authorization number (RMA). See contact information in [Chapter 1, Section 1.2](#).